

QHC/QHC+ Series Counting Scales



► Features:

- 20mm LCD display, white LED backlight
- 20 keys (embossed membrane keyboard)
- Functions include: quantity alarm, check weighing and piece weight update
- Battery provides up to 90 hours of continuous use

► Options:

- RS-232 output to connect to computer, LP-50 label printer, TPU P mini printer

► Specifications:

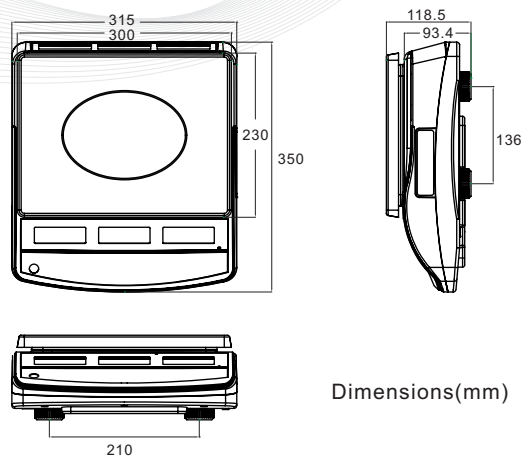

Model	QHC-3	QHC-3+	QHC-6	QHC-6+	QHC-15	QHC-15+	QHC-30	QHC-30+
Display	20mm LCD display , white LED backlight							
Capacity	3kg		6kg		15kg		30kg	
Readability	0.1g	0.05g	0.2g	0.1g	0.5g	0.2g	1g	0.5g
Pan size	230mm x 300mm							
Keyboard	20 keys (embossed membrane keyboard)							
Housing	ABS plastic							
Max. Divisions	30000/60000d							
ADC	Sigma delta							
ADC update	≤1/10 second							
Operate. Temp.	0°C~ +40°C							
Power	AC adapter (9V/500mA) internal rechargeable battery (6V/4Ah)							
Gross weight	5.1kg							
Packing	Master carton 4 in 1, gross weight 23.5kg, dimension 0.162 m ³							